

VIII. Appendix

(2). General Packaging Information for SMD Devices (Tape in Reel)

a). Tape Dimensions and Orientation: (Dimensions in mm)

8mm

SOT-23

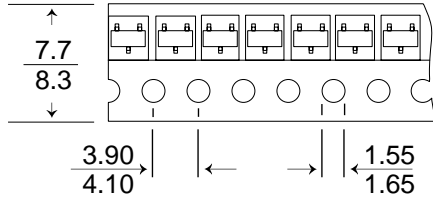

SOD-123/323/523

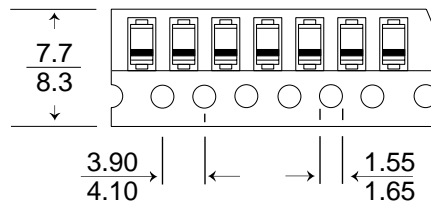

12mm

SMA

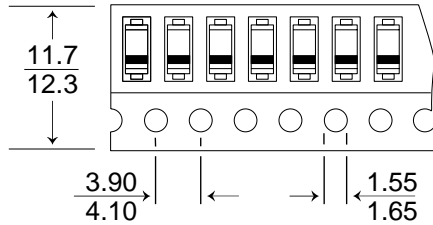

SMB

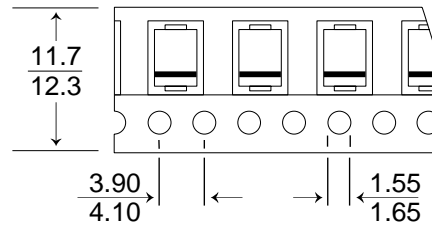

MELF

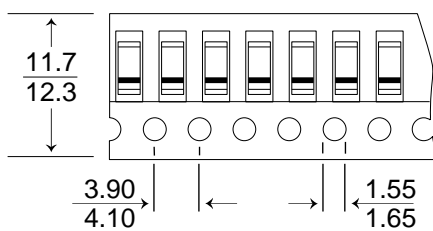

MiniDIP

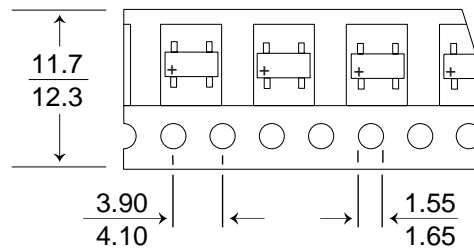

16mm

DBS

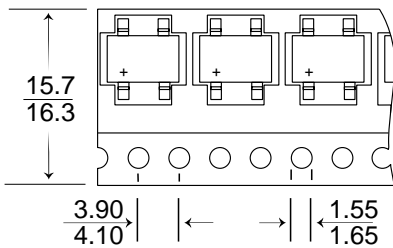

SMC

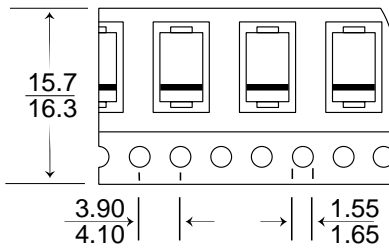

VIII. Appendix

(2). General Packaging Information for SMD Devices

b). Embossed Carrier Tape specifications (Dimensions in mm)

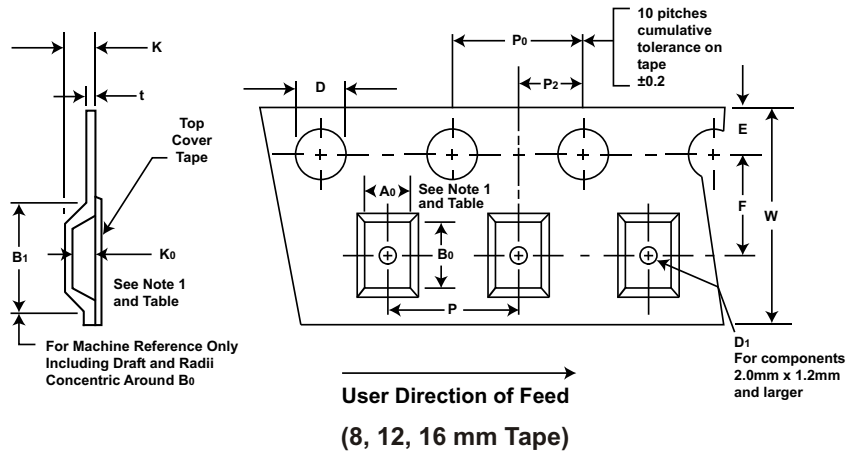

8, 12, 16 mm EMBOSSED TAPE DIMENSIONS IN mm						
Tape Size	D	E	P ₀	t max	Ao Bo Ko	Constant Dimensions
8, 12, 16 mm	1.55 +0.10 -0.0	1.75 ± 0.10	4.0 ± 0.10	0.400	See Note 1	

Tape Size	B ₁ max	D ₁ min	F	K max	P ₂	R min	W	Product Type
8mm	4.5	1.0	3.5 ± 0.05	2.4	2.0 ± 0.05	25	8.0 ± 0.30	SOT-23, Mini-MELF, SOD-123, SOD-323, SOD-523
12mm	8.2	1.5	5.5 ± 0.05	4.5	2.0 ± 0.05	30	12.0 ± 0.30	MELF, SMA, SMB, Mini-DIP
16mm	12.1	1.5 1.5	7.5 ± 0.10 7.5 ± 0.10	3.29 3.70	2.0 ± 0.10 4.0 ± 0.10	40	16.0 ± 0.30 16.0 ± 0.30	SMC, DBS

Tape Size	P				
	2.0 ± 0.05	4.0 ± 0.10	8.0 ± 0.10	12.0 ± 0.10	16.0 ± 0.10
8mm	—	SOT-23, Mini-MELF, SOD-123, SOD-323, SOD-523	—	—	—
12mm	—	SMA, MELF	SMB, Mini-DIP	—	—
16mm	—	—	SMC	DBS	—

Notes :

1. Ao Bo Ko are determined by component size. The clearance between the component and the cavity must be with 0.05mm min. to 0.50mm max. for 8mm tape, 0.05mm min. to 0.65mm max. for 12mm tape and 0.15mm min. to 0.90mm max. for 16mm tape.

VIII. Appendix

(2). General Packaging Information for SMD Devices (Tape in Reel)

c). Surface Mount Reel specifications (Dimensions in mm)

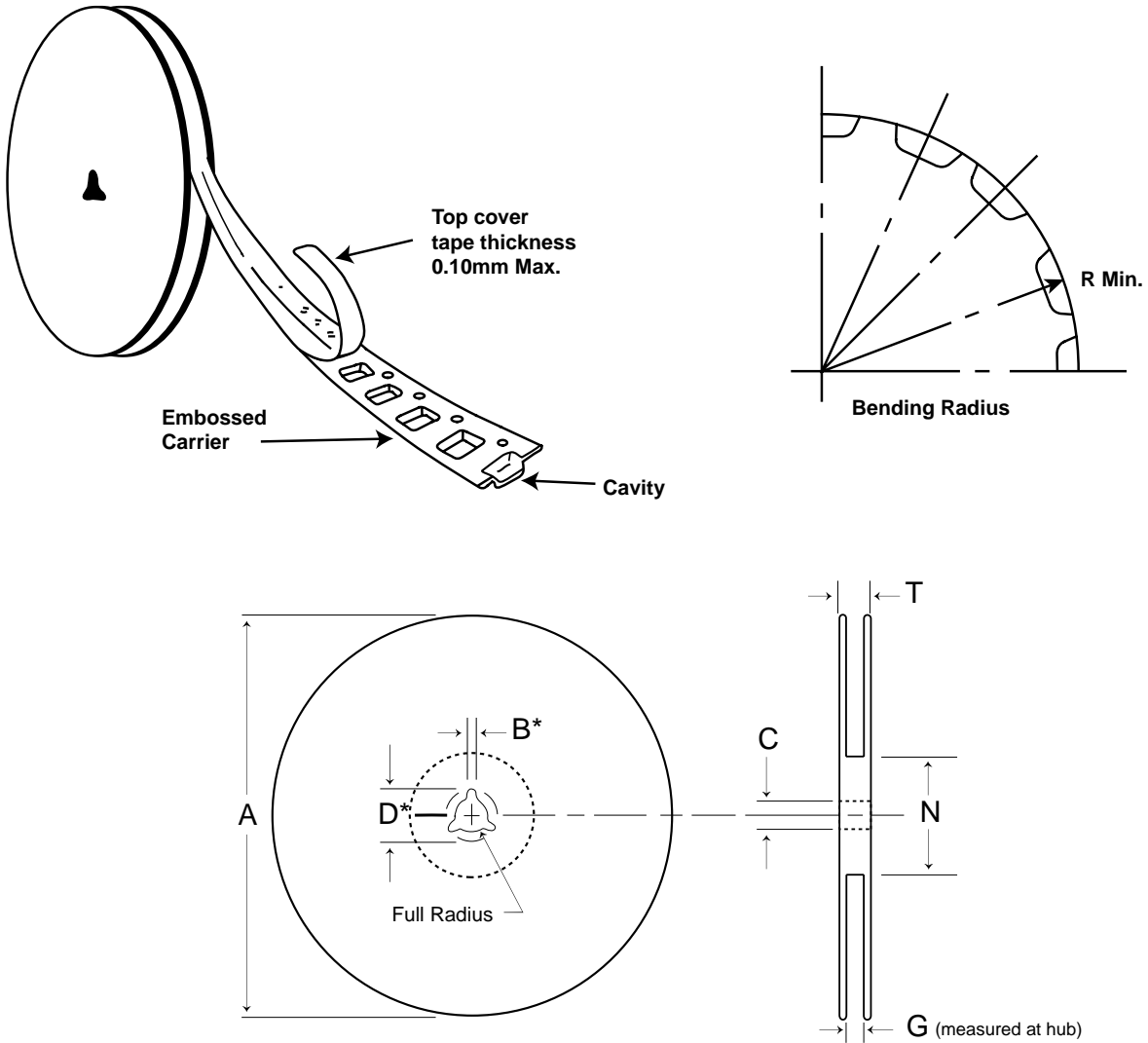

* Drive spokes optional. If used, dimensions with asterisks apply.

Tape Size	A max	B* max	C	D* max	N min	G	T max
8mm	180	1.5	13.0 ± 0.20	20.2	50	8.4 +1.5 -0.0	14.4
12mm	330	1.5	13.0 ± 0.20	20.2	50	12.4 +2.0 -0.0	18.4
16mm	330	1.5	13.0 ± 0.20	20.2	50	16.4 +2.0 -0.0	22.4

VIII. Appendix

2). General packing information for SMD Devices

c) Surface mount packing box 34cm x 34cm x 4cm :

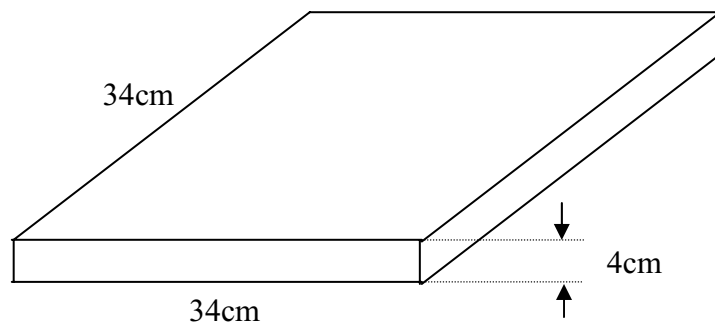

Product Type	Tape Size	Qty/Reel	Reel / Box	Qty / Box
MELF	12mm	5000	2	10000
SMA		5000		10000
SMB		3000		6000
Mini-DIP		3000		6000
SMC	16mm	3000		6000
DBS		3000		6000

d) Surface mount packing box 19.2cm x 19.2cm x 7.7cm :

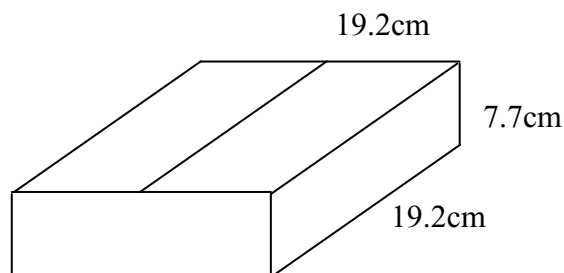

Product Type	Tape Size	Qty/Reel	Reel / Box	Qty / Box
Mini-MELF	8mm	2500	5	12500
SOD-123		2500, 3000		12500, 15000
SOD-323		3000		15000
SOD-523		3000		15000
SOT-23,		3000		15000

VIII. Appendix

2). General packing information for SMD Devices

e) Packaging labelling (Melf, SMA, SMB, SMC, MBS)

